

SOT-23 Plastic-Encapsulate Transistors

Features

- Epitaxial planar die construction.
- Complementary PNP type available (MMBT2907)
- NPN General Purpose Amplifier

MECHANICAL DATA

- Case style: SOT-23 molded plastic
- Mounting position: any

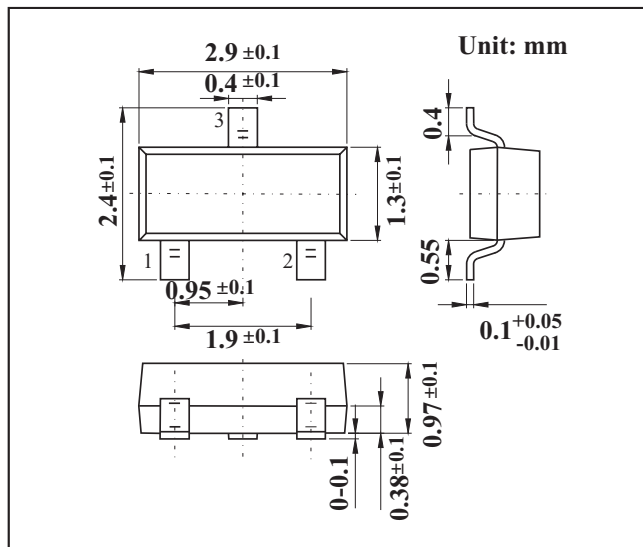

MAXIMUM RATINGS AND CHARACTERISTICS

@ 25°C Ambient Temperature (unless otherwise noted)

Parameter	Symbol	Rating	Unit
Collector-base voltage	V _{CB0}	60	V
Collector-emitter voltage	V _{CEO}	30	V
Emitter-base voltage	V _{EBO}	5	V
Collector current	I _C	600	mA
Power dissipation	P _D	250	mW
Thermal resistance from junction to ambient	R _{θJA}	500	°C/W
Operating and Storage and Temperature Range	T _j , T _{STG}	-55 to +150	°C

PACKAGE INFORMATION

Device	Package	Shipping
2SD1782	SOT-23	3000/Tape&Reel

Parameter	Symbol	Test conditions	Min	Typ	Max	Unit
Collector-Base Breakdown Voltage	V _{(BR)CBO}	I _C = 10 μA, I _E = 0	75			V
Collector-Emitter Breakdown Voltage	V _{(BR)CEO}	I _C = 10 mA, I _B = 0	40			V
Emitter-Base Breakdown Voltage	V _{(BR)EBO}	I _C = 10 μA, I _C = 0	6			V
Collector cutoff current	I _{CBO}	V _{CB} = 50V, I _E = 0			10	nA
Emitter cutoff current	I _{EBO}	V _{EB} = 3V, I _C = 0			100	nA
DC current gain	h _{FE}	V _{CE} = 10V, I _C = 0.1mA	35			
		V _{CE} = 10V, I _C = 150mA	100		300	
		V _{CE} = 10V, I _C = 500mA	30			
collector-emitter saturation voltage *	V _{CE(sat)}	I _C = 150 mA; I _B = 15 mA			0.4	V
		I _C = 500 mA; I _B = 50 mA			1.6	V
base-emitter saturation voltage *	V _{BE(sat)}	I _C = 150 mA; I _B = 15 mA			1.3	V
		I _C = 500 mA; I _B = 50 mA			2.6	V
Transition frequency	f _T	I _C = 20 mA; V _{CE} = 20 V; f = 100 MHz	250			MHz
Delay time	t _d	V _{CC} = 30V, V _{BE(off)} = -0.5V,			10	ns
Rise time	t _r	I _C = 150mA, I _{B1} = 15mA			25	ns
Storage time	t _s	V _{CC} = 30V, I _C = 150mA, I _{B1} = -I _{B2} = 15mA			225	ns
Fall time	t _f				60	ns

* pulse test: Pulse Width ≤ 300μs, Duty Cycle ≤ 2.0%.

Marking

Marking	M1B
---------	-----